

# SATURN

20HS1500-BK-SV  
20HS2000-BK-SV

## HIGH SPEED FLOOR MACHINE

OWNER'S/OPERATOR'S MANUAL

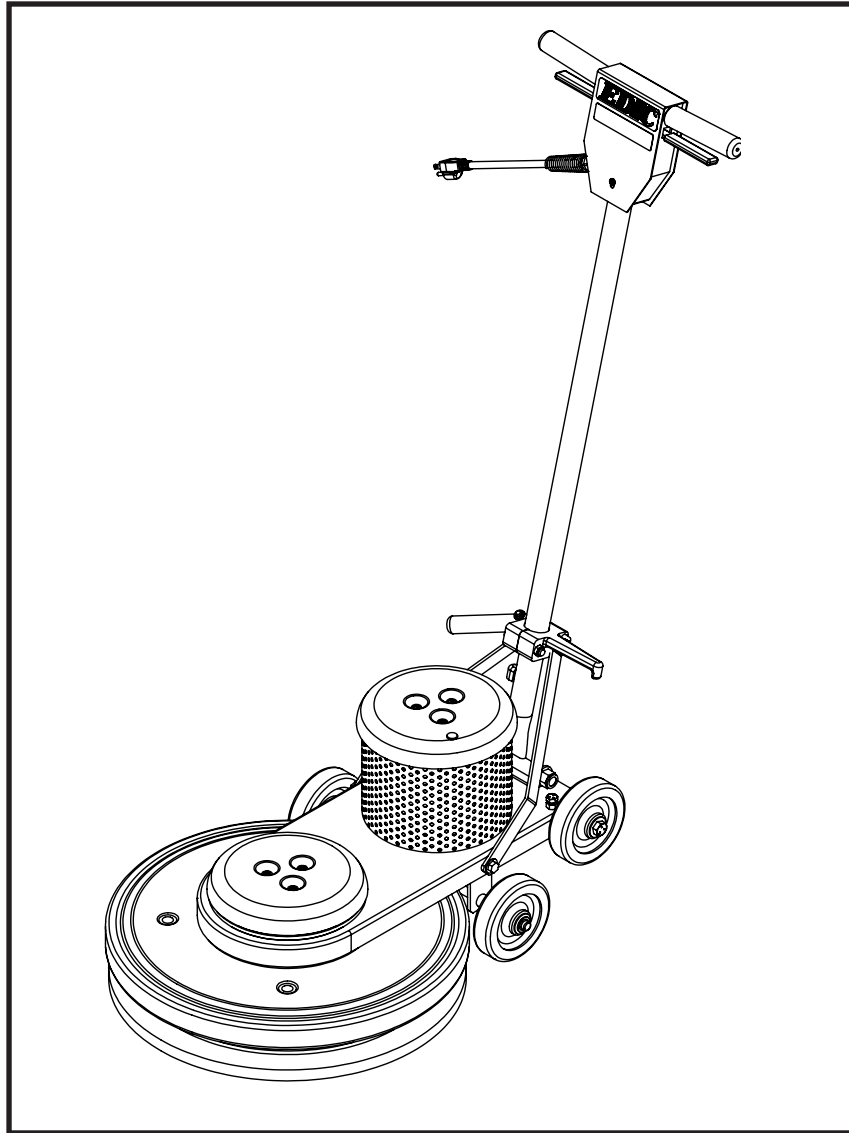

## TABLE OF CONTENTS

RECEIVING YOUR EQUIPMENT.....	3
WARNINGS AND SAFETY.....	3-4
ELECTRICAL INFORMATION.....	4
GROUNDING INSTRUCTIONS.....	4
MAINTENANCE.....	5
CORD SAFETY AND STORAGE.....	5
CLEANUP AND STORAGE.....	5
MAINTENANCE, CLEANUP, STORAGE.....	5
PAD INSTALLATION.....	5
DRIVE BELT ADJUSTMENTS.....	6
MACHINE OPERATION.....	7
MANEUVERING THE MACHINE.....	7
SERVICING.....	7
FINAL ASSEMBLY PROCEDURE.....	8-15
EXPLODED VIEW: BOTH MODELS.....	16-17
1500 RPM MODEL PARTS LIST.....	18-20
2000 RPM MODEL PARTS LIST .....	21-23

### RECEIVING YOUR NEW SATURN:

When your package is delivered, check all cartons carefully for signs of rough handling. If your SATURN is damaged, notify the carrier immediately and request an inspection. Be sure to keep all cartons, packing inserts, packing lists and carrier's receipt until the inspector has verified your claim.

EDIC's liability ceases when the carrier picks up the shipment. However, our customer service staff will be happy to furnish any information needed in connection with the claim and will attempt to expedite a resolution.



### PLEASE READ BEFORE OPERATING YOUR NEW SATURN:

Read the manual carefully and completely before attempting to operate the unit. This manual has important information for the use and safe operation of the machine. Keep this manual handy at all times.

This equipment has been engineered and manufactured to provide excellent performance and service. To ensure that your equipment will continue to perform as intended:

- Maintain equipment regularly- following the suggested maintenance schedule provided.
- Use only original EDIC parts when servicing.
- Operate equipment with care.

If additional information is needed, please contact:  
**EDIC 800-338-3342**

All information and specifications printed in the manual are current at the time of printing; however because of EDIC's policy of continual product development, we reserve the right to make changes at any time without notice.

### FAILURE TO COMPLY WITH THE FOLLOWING WARNINGS AND INSTRUCTIONS WILL VOID THE WARRANTY.

#### WARNING!

- Do not operate the machine unless trained and authorized.
- Do not allow children or untrained adults to operate this machine.
- Do not leave the machine when plugged in. Unplug from the outlet when not in use, before servicing, and when changing the brushes or pads.
- Use indoors only.
- Do not allow to be used as a toy. Close attention is necessary when used by or near children.
- Do not bypass or defeat the safety "lock-out lever."
- The machine was designed for use as per instruction and recommendations written in this manual.
- Any deviation from its proper use or purpose and the consequential damage that may occur is the sole responsibility of the end user.
- Do not use with damaged cord or plug. If the machine is not working as it should, or it has been dropped, damaged, left outdoors or dropped into water, return it to an authorized service center.
- Do not pull or carry by cord, use cord as handle, close a door on the cord or pull cord around sharp edges or corners. Do not run machine over cord. Keep cord away from heated surfaces.
- Do not unplug by pulling on cord. To unplug, grasp the plug, not the cord.
- Do not handle plug or appliance with wet hands.
- Make sure the machine is plugged into an electrical outlet with the same voltage and frequency rating as shown on the nameplate of the machine. Do not attempt to plug a 115- volt machine into a 230- volt outlet.
- Do not immerse or use this machine in standing water. Such use can cause electric shock.
- Keep the electrical supply cord from contacting the rotating brush or drive block.
- Do not expose machine to freezing temperatures.
- To avoid electric shock, do not expose the unit to rain. Store indoors only.

- Connect to a properly grounded outlet only. See “Grounding Instructions.”
- Turn off all controls before unplugging.
- When using an extension cord, use a 3 conductor grounding cord, 12 gauge wire or heavier.
- Do not put any object into openings. Do not use with any opening blocked. Keep free of dust, lint,
- hair and anything that may reduce air flow.
- Do not operate machine in flammable or explosive areas.
- All servicing of EDIC’s equipment should be performed by a EDIC authorized service center.
- Keep hair, loose clothing, fingers and all parts of body away from openings and moving parts.
- Use extra care when cleaning near stairs.
- To reduce the risk of fire use only commercially available floor cleaners and waxes intended for machine application.
- Risk of explosion - Electrical motors and components can cause an explosion when operated near volatile materials and vapors. Do not use this machine near flammable materials such as solvents, thinners, fuels, grain dust, etc.



### **ELECTRICAL - 115 Volt**

**Model: ALL LISTED ON COVER WITHOUT “-220V”**

This machine is designed to operate on a standard 15 amp, 120 volt, 60 Hz, AC circuit. Voltages below 105 volt AC or above 125 volts AC could cause serious damage to the motor.

### **ELECTRICAL - 240 Volt**

**Model: ANY MACHINES WITH A “-220V” AT THE END OF MODEL NUMBER**

This machine is designed to operate on a standard 8.3 amp type L fused 230 volt, 50 Hz, AC circuit. Voltages below 200 volt AC or above 250 volts AC could cause serious damage to the motor.

### **GROUNDING INSTRUCTIONS:**

This piece of equipment must be grounded. Should an electrical malfunction occur, grounding provides a path of least resistance for electrical current- reducing the risk of electric shock. This piece of equipment is furnished with a cord that has a grounding conductor and grounding plug. The grounded plug must only be plugged into an appropriate outlet that is properly installed and grounded in accordance with all local codes and ordinances.

### **WARNING:**

Connecting the equipment to an improperly grounded outlet can result in an increased risk of electric shock. A qualified electrician should be consulted if you are unsure that the outlet is properly grounded. Do not modify the plug provided with the equipment. If it will not fit the outlet, have a proper outlet installed by a qualified electrician.

This appliance is designed for use on a 120-volt circuit. The grounding plug provided looks like the plug illustrated in Figure 1. Replace the power cord if the grounding pin is damaged or broken.

Extension cords connected to this machine should be 12 gauge, three-wire cords with three-prong plugs and outlets. **DO NOT** use extension cords more than 25 feet (7.6 m) long

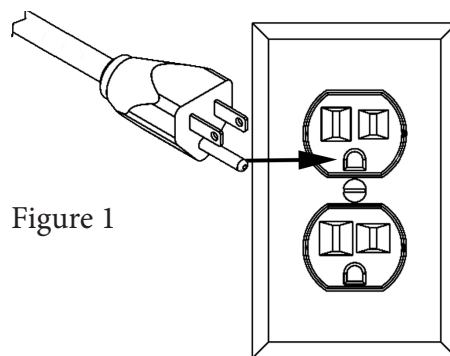

Figure 1

## CORD SAFETY

- Do not leave appliance when plugged in. Unplug from outlet when not in use and before servicing
- Do not use with damaged cord or plug. If appliance is not working as it should, has been dropped, damaged, left outdoors, or dropped into water, return to service center for inspection and repair.
- Do not pull or carry by cord, use cord as handle, close a door on cord, or pull cord around sharp edges or corners. Do not run this SATURN over the cord. Keep cord away from heated surfaces.
- Do not unplug by pulling cord. To unplug, grasp the plug, not the cord.
- Do not handle plug or appliance with wet hands.
- Always unplug the machine when removing brush.
- This equipment should be stored indoors and not exposed to rain.

## CORD STORAGE:

While not in use, storage can be accomplished by winding cord around handle assy. Cord should be completely unwound during operation.

## MAINTENANCE:

This SATURN has been engineered and built to require minimum maintenance. But like any machine, it does require some care to keep it in optimum working condition. Careful attention to these maintenance instructions will give you maximum operating performance and life expectancy of the machine.

## CAUTION: Disconnect the power cord from the outlet before doing any clean up or maintenance on the machine

1. Keep the machine clean. Do not allow dust to accumulate on external surfaces, the motor, or near any moving parts.
2. After every job, wipe down the surface of the machine with a clean damp cloth.
3. Inspect cord for damage. Do not use machine with a damaged cord.

## CLEAN UP & STORAGE

1. Unplug and wrap it under the cord hook and around the left side handle grip. Clean the cord and inspect it for cuts, gashes and loose prongs.
2. Wipe down the machine and store in clean dry place.
3. To prevent deformation of pad and pad driver, remove them before storing.
- 4.

**WARNING:** Do not store the machine with the drive block, pad driver or brush on the machine.

## PAD INSTALLATION:

1. To install pad, tilt the machine back on the rear wheels until machine is resting on handle.
2. Center the pad on the pad holder and insert pad center lock. Twist clockwise to lock. Make sure the center lock is tight.

To remove: Twist the center lock counterclockwise

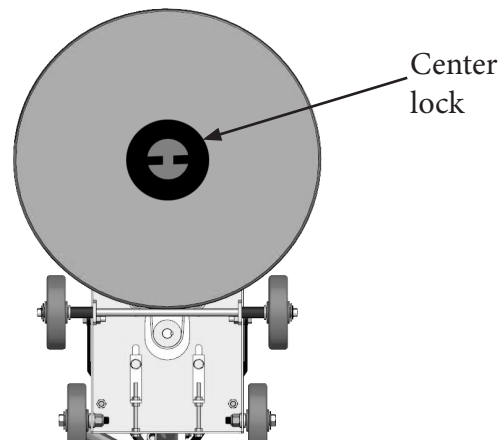

3. Use the appropriate pads for the floor condition and surface. Lighter pads are less abrasive and darker pads are more abrasive. The correct pad will give you the best results. Consult your local distributor for recommendations.
4. Do not use pads that are larger than 20" in diameter.

## TO ADJUST A DRIVE BELT

1. Locate the motor pulley on the underside of the machine. It will be the only pulley visible. There will be 4 motor mounting bolts surrounding it. These bolts fasten the motor to the frame and can move along the slotted opening. Loosen, but do not remove, the 4 bolts.

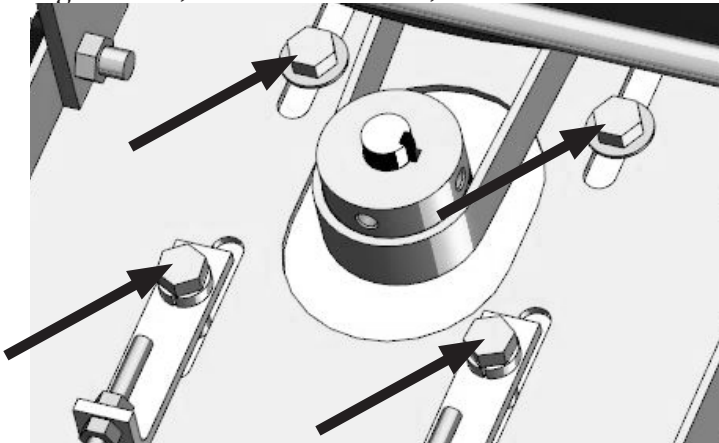

2. Locate the two belt tensioners at the rear of the machine

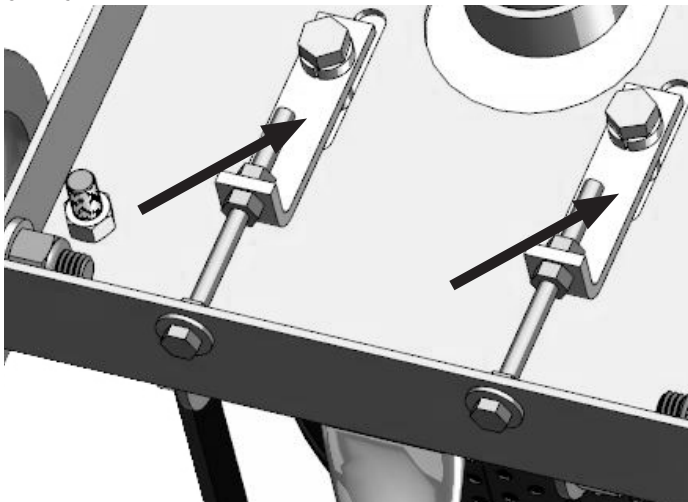

- 3.
4. On the belt tensioners, locate the two jam nuts. There is a front and a rear.

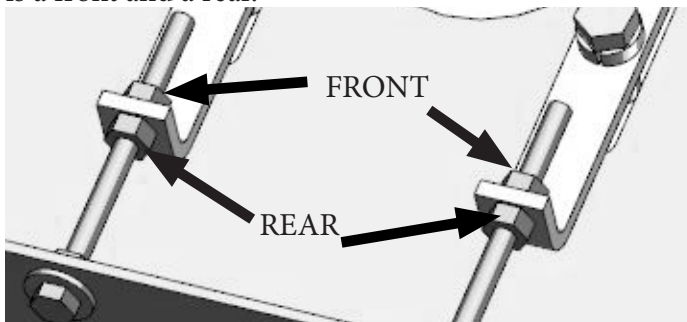

- 5.

6. To reduce belt tension, loosen the front jam nut and tighten the rear.
7. To increase tension, loosen the rear jam nut and tighten the front.
8. Always adjust both tensioners exactly the same way.
9. Once the belt has reached appropriate tension, tighten the jam nuts.
10. Tighten the 4 motor mounting bolts, test and adjust until the belt does not slip.

**WARNING: DO NOT OVER-TIGHTEN THE BELT. ALWAYS TIGHTEN OR LOOSEN IN SMALL INCREMENTS.**

### SERVICING:

In the event that your SATURN requires service, please contact EDIC:  
**800-338-3342**

No user serviceable components are employed in this equipment. Do not attempt repairs yourself. EDIC will assist you in locating an independent service contractor.

## MACHINE ON/OFF OPERATION:

This equipment is equipped with a safety “LOCK OUT” lever. Refer to Diagram 1 for steps 5, 6, and 7.

1. Install the pad driver and pad or attachment.
2. Plug in machine.
3. Lean the machine back, with all four wheels on the floor, so the pad is not making contact with the floor when you turn the motor on.
4. Place both hands on the handle grips with your fingers around the ON/OFF lever (Refer to B on Diagram 1) Which extends from one side to the other, underneath the handle grips.
5. The safety “LOCK OUT” lever (Refer to A on Diagram 1) is located underneath the right side handle grip and switch lever. To unlock the “LOCK OUT” lever, use your right hand fore finger to press the lever toward the back of the switch box.
6. With “LOCK OUT” lever in the unlocked position, pull up on either side of the ON/OFF lever (Refer to B on Diagram 1) to power the motor. Pull up on only one side of the ON/OFF lever.
7. Wait 5 seconds for the motor to reach full speed and place pad on the floor.

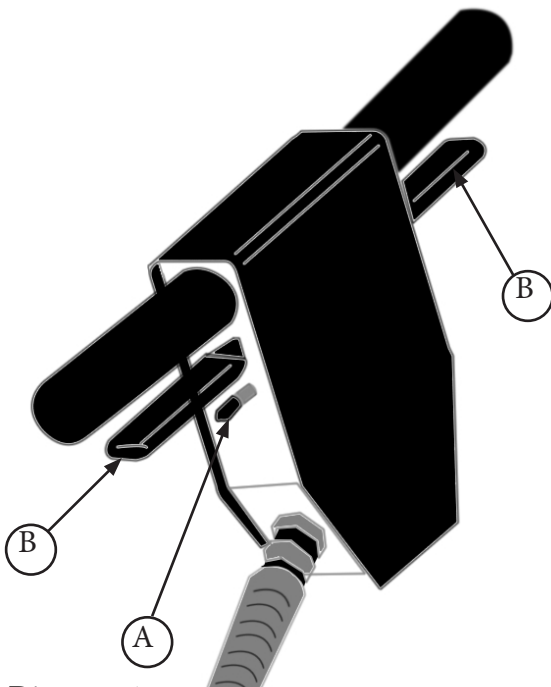

Diagram 1

## TO MANEUVER THE MACHINE:

### CAUTION:

THIS MACHINE CANNOT BE OPERATED WITH THE HANDLE IN THE UPRIGHT POSITION. DOING SO WILL CAUSE LOSS OF CONTROL AND POSSIBLE INJURY.

1. Lower the handle to a comfortable height for the operator. This machine should operate with the handle unlocked at about waist level. Do not lock the handle into a fixed position.
2. It is best that the operator begin operation closest to the power outlet and move outward as far as the power cord will permit, then, work back to the original point.
3. Move the machine in forward and reverse. Do not swing side to side.
4. To stop the machine, simply release ON/OFF levers.
5. Do not use on wet floors.

## HS Floor Machine SV Unit Final Assembly Procedure

Rev.00          2.13.2019

### Models:

20HS2000-BK-SV

20HS1500-BK-SV

### Tools Required:

- 5/16" Allen Wrench (included)
- A pair of adjustable wrenches or
  - (2x) 3/4" Wrench
  - (1x) 9/16" Wrench
  - (1x) 7/8" Wrench
  - (1x) 13/16" Wrench

### Assembly Instructions:

1. Remove rear right-wheel assembly with a pair of adjustable wrenches or (2x) 3/4" wrenches.

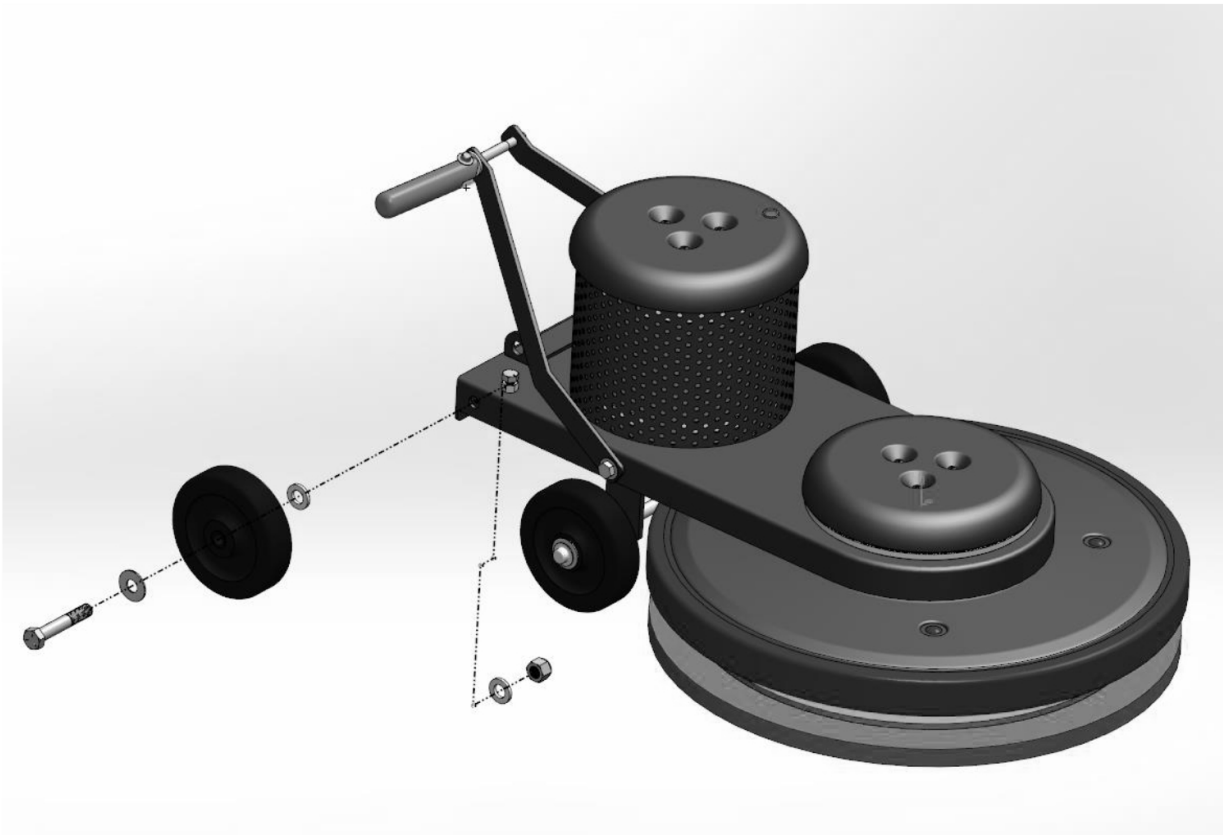



2. Next, remove handle locking lever from handle braces with 9/16" wrench.

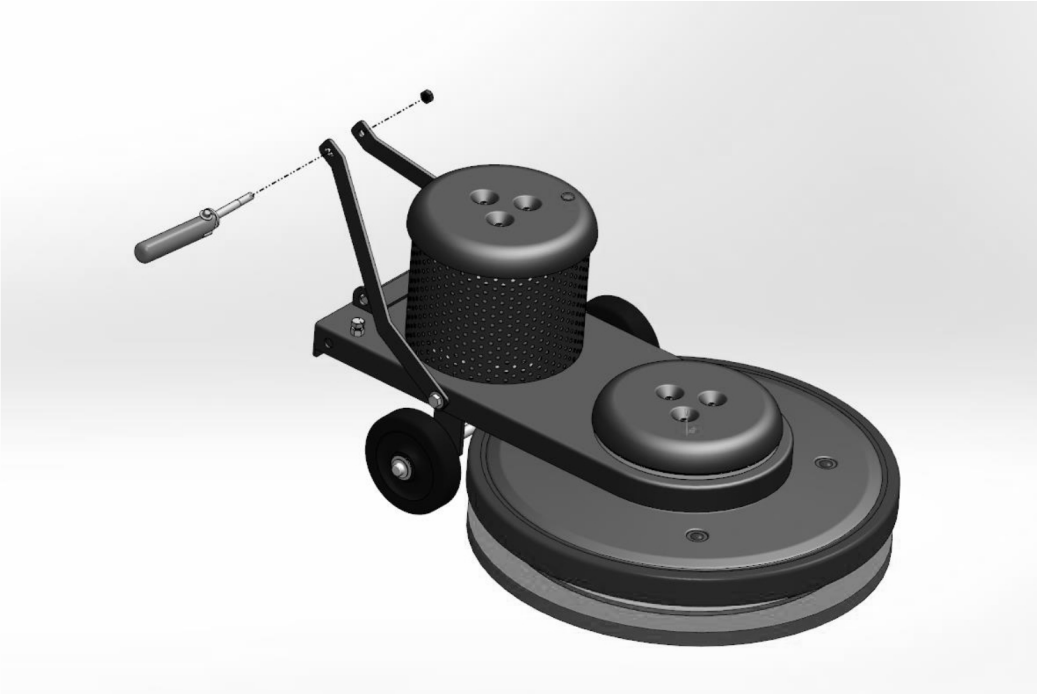

3. Attach handle assembly to the rear of the motor base and secure with included nut (C13100) and bolt (C13101).



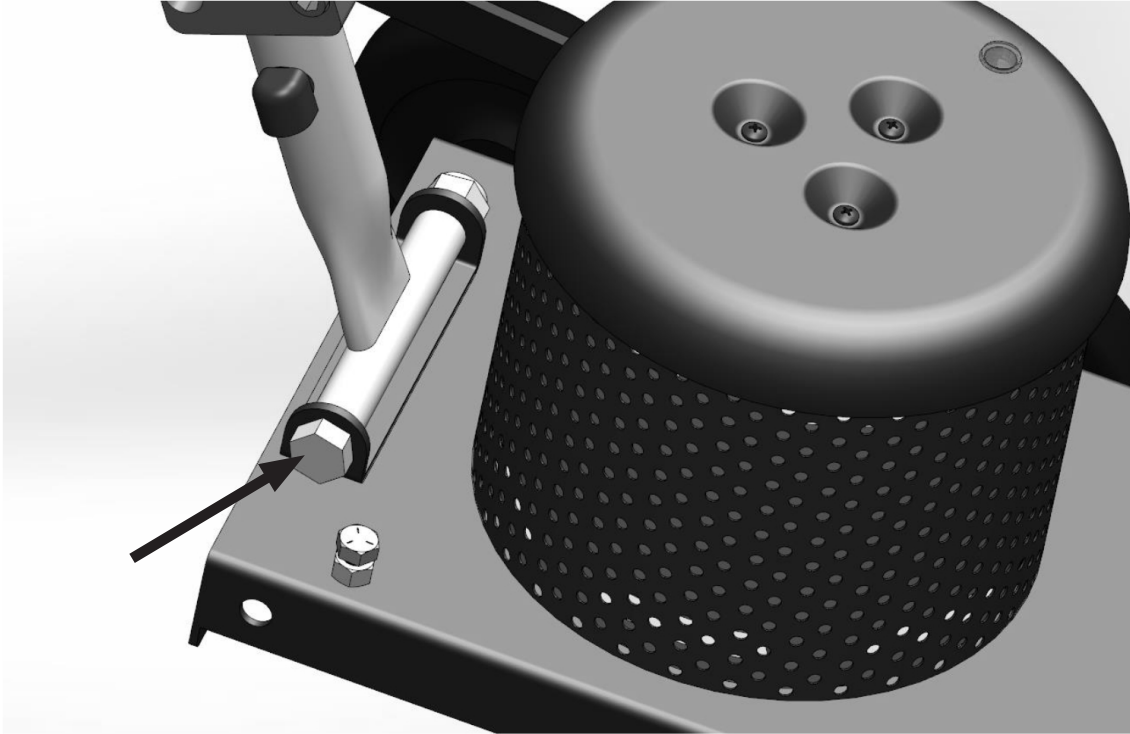

5. Re-install Handle Locking Lever to Handle Brace and Handle clamp assembly. Do not fully tighten Handle Locking Lever assembly yet.



6. Do not fully tighten Handle Locking Lever assembly yet. Adjustment for proper tension and locking will be necessary after the unit is fully assembled. Refer to Instructions for Locking Lever Adjustment in the next section.



7. Re-install rear right-wheel assembly (C14724, C11559-1, G11943, C00240(2x), C14725). Do not overtighten wheel assembly. The wheel should be able to spin freely with no backlash.

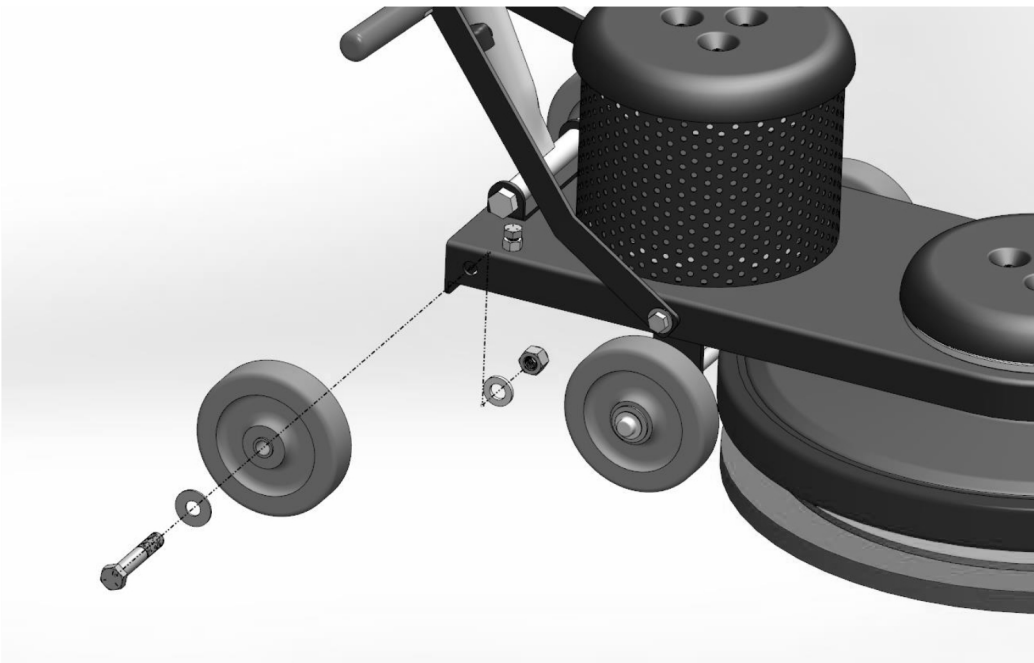

8. Assembly is complete. Proceed to adjust Handle Locking Lever Assembly.



### Handle Locking Lever Adjustment:

1. Put the handle in the unlock position (up position) and start tightening the nut C11558 on the threaded portion of the spade bolt (C11536).

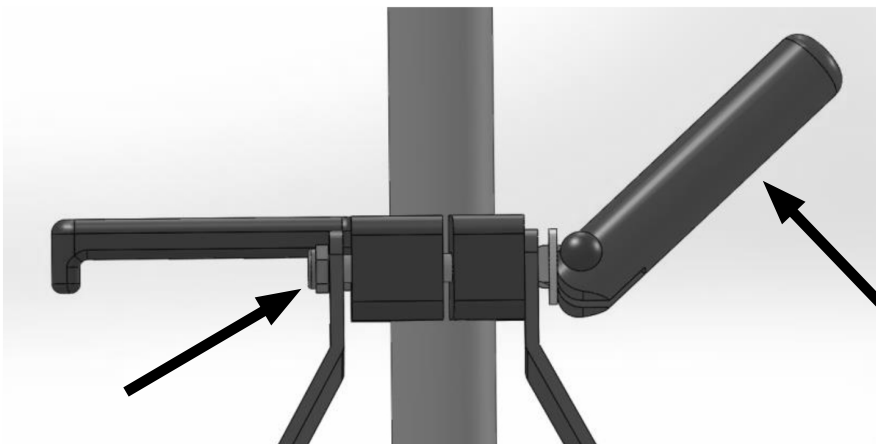

2. Check that the cord-hook clamp is sliding up and down freely on the handle stem while in the unlock position.

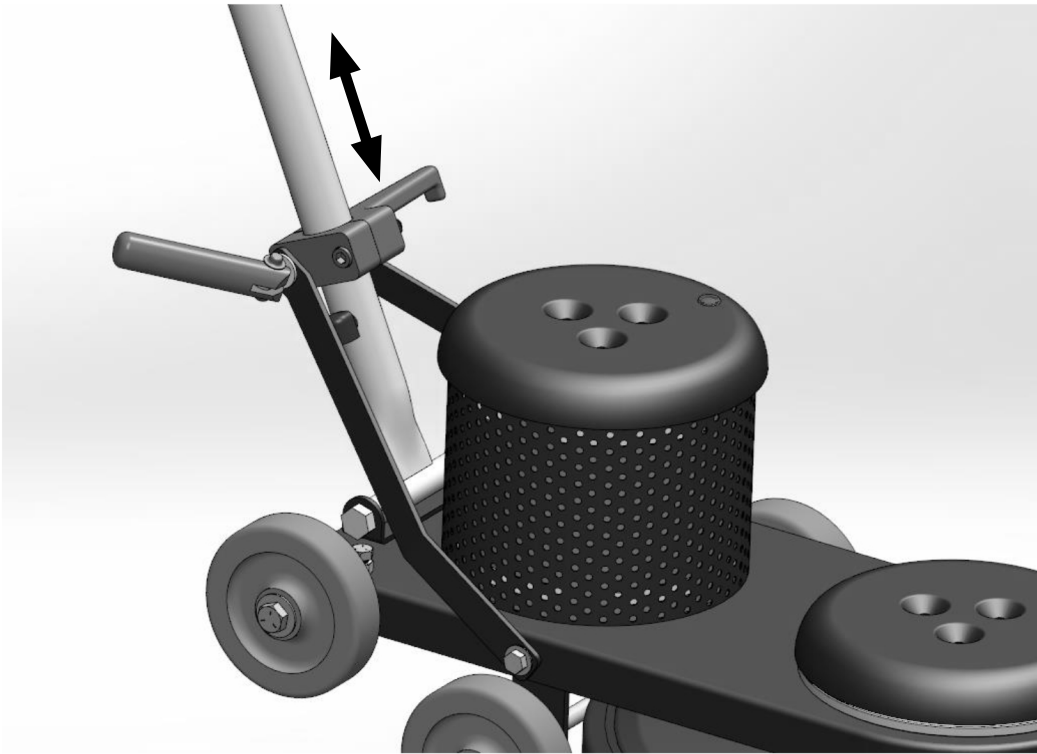

3. Frequently stop and lock the handle (down position) to check if it is tight enough. The cord-hook clamp should not slide while in the locked position when properly tightened.

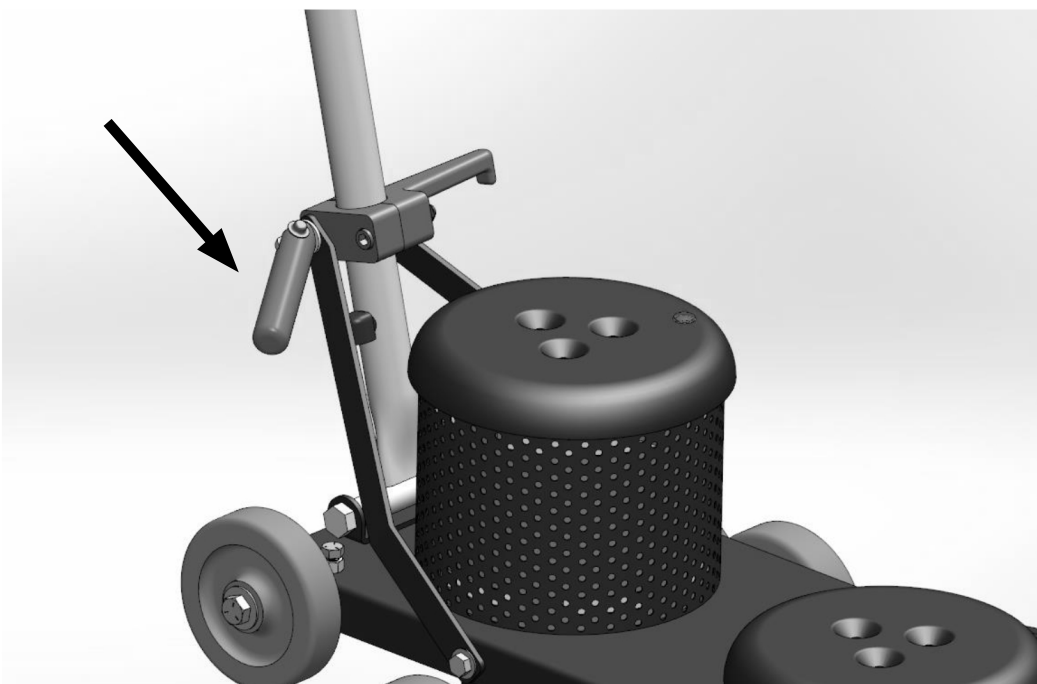

4. Repeat this process and tighten the nut until you feel the down position of the handle is firmly locking and up position of the handle is unlocking well.

## Handle Height Adjustment:

1. Handle height during operation can be adjusted to accommodate a slightly higher position.



2. To adjust handle height setting for operation, loosen the two jam nuts on the brace-stops, then adjust the two brace-stop bolts and in equal amounts to the desired height setting.

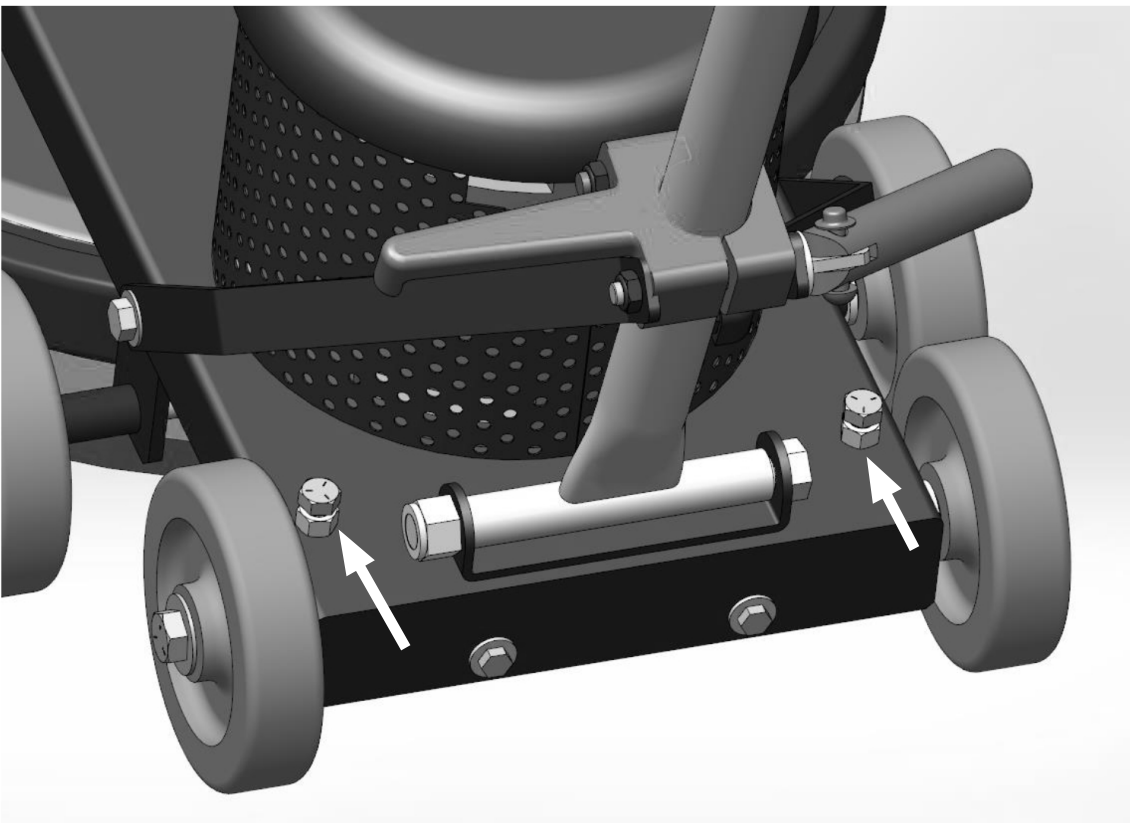

3. Be careful not to over-extend the brace-stop bolts. Check to make sure the handle braces make full contact with the brace-stop bolts when handle is in lowest position.

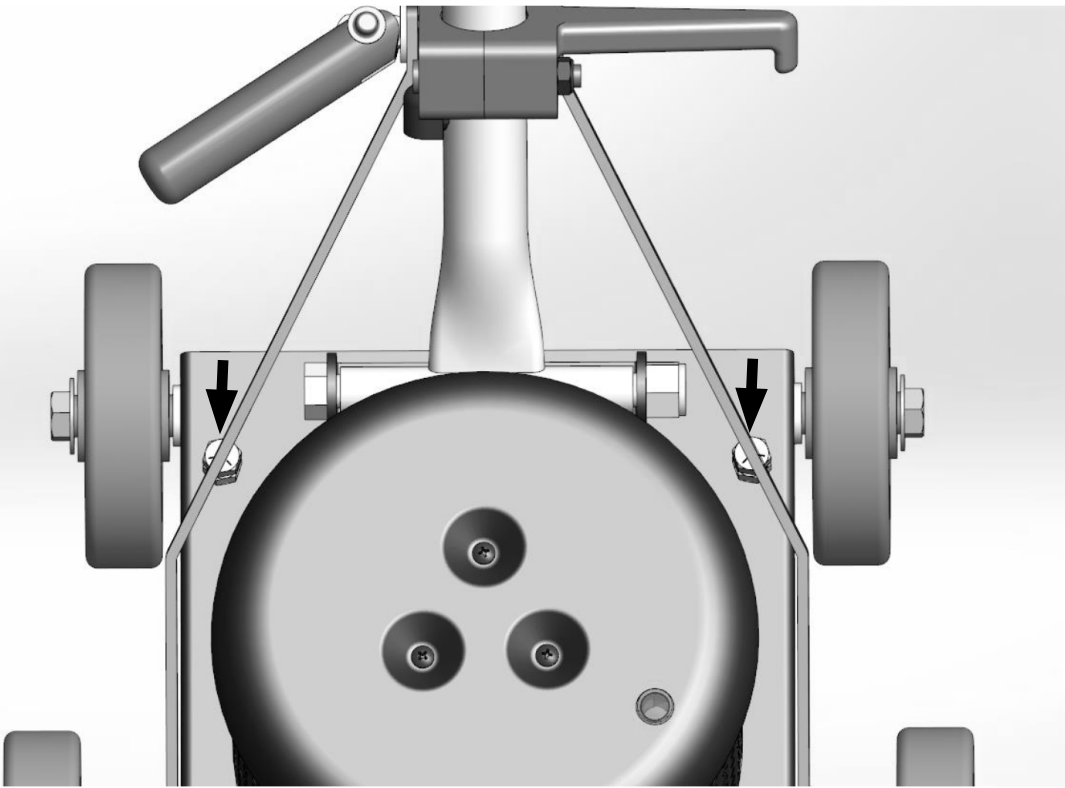

4. Once the desired height setting is achieved, tighten the two jam nuts on the brace-stop bolts on each side.

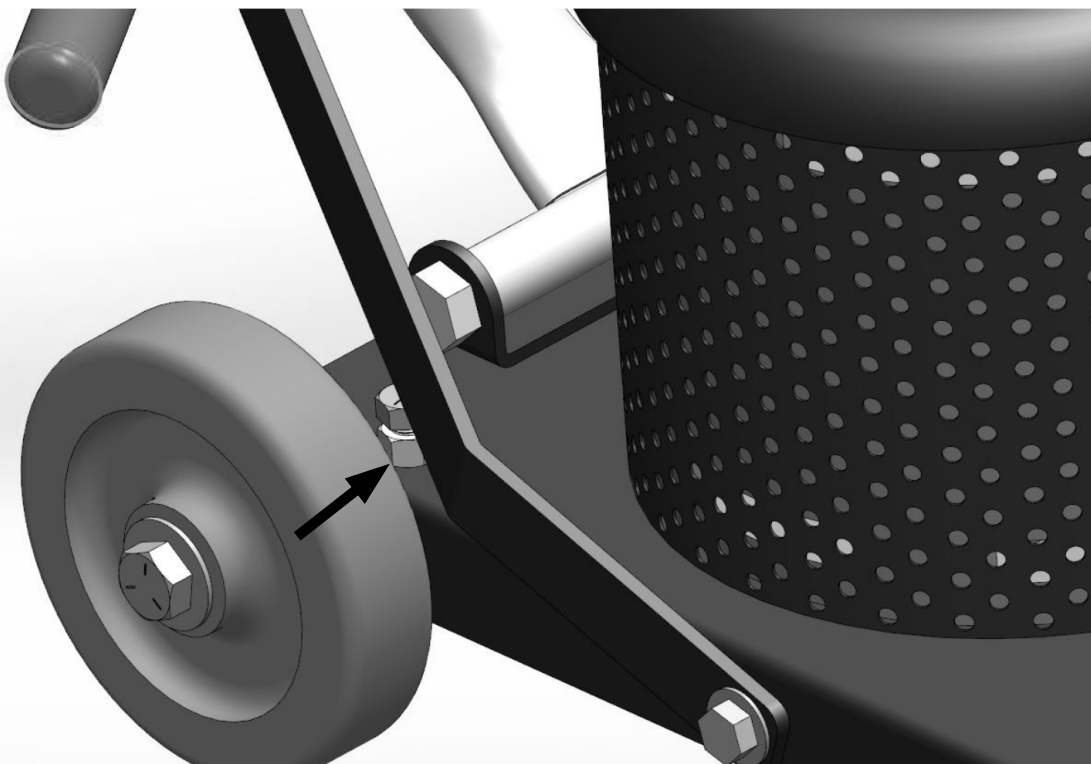

20HS1500-BK-SV &  
20HS2000-BK-SV  
FLOOR MACHINE BASE  
ASSEMBLY EXPLODED  
VIEW

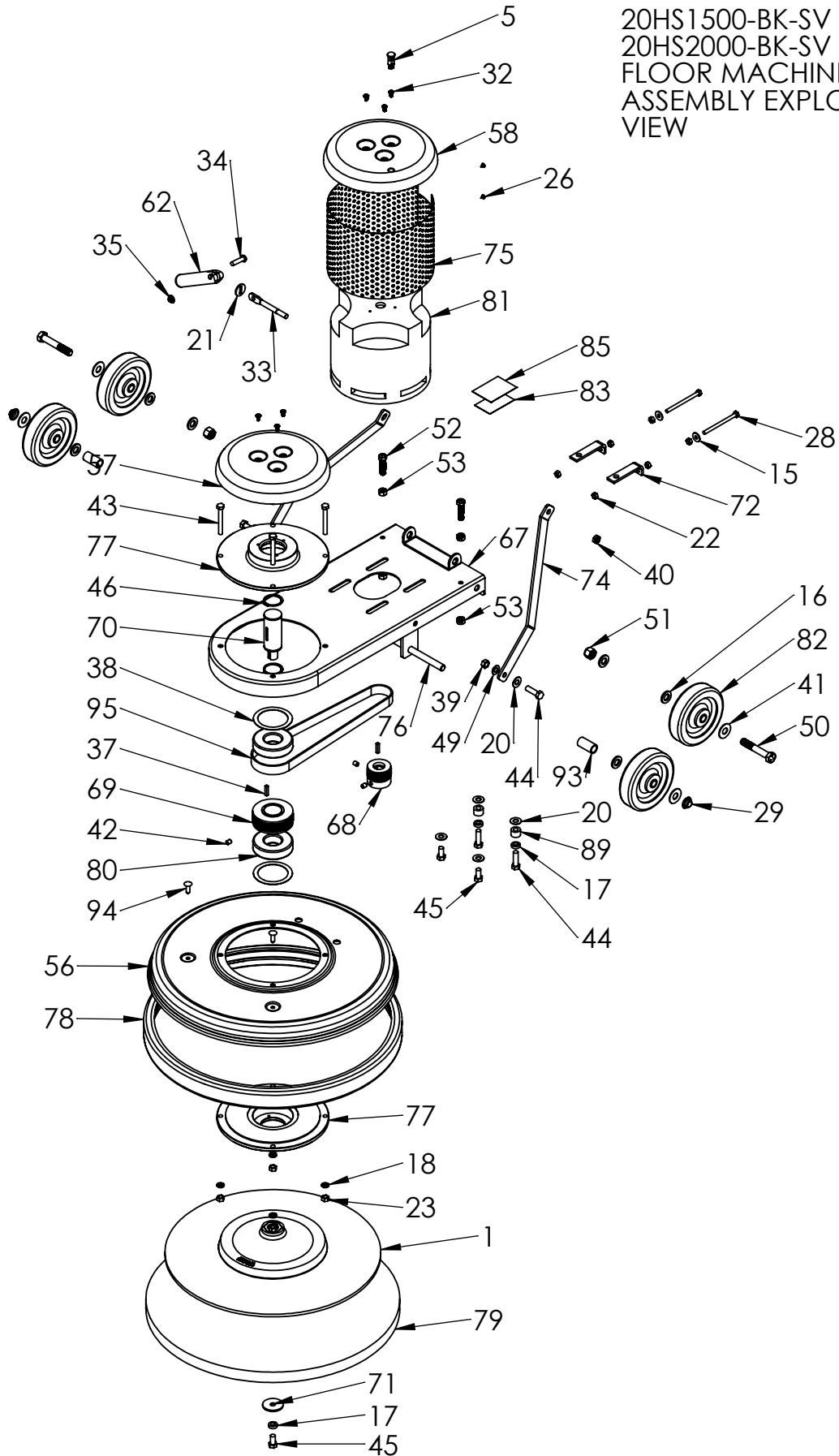



20HS1500-BK-SV &  
20HS2000-BK-SV  
FLOOR MACHINE  
HANDLE ASSEMBLY  
EXPLODED VIEW

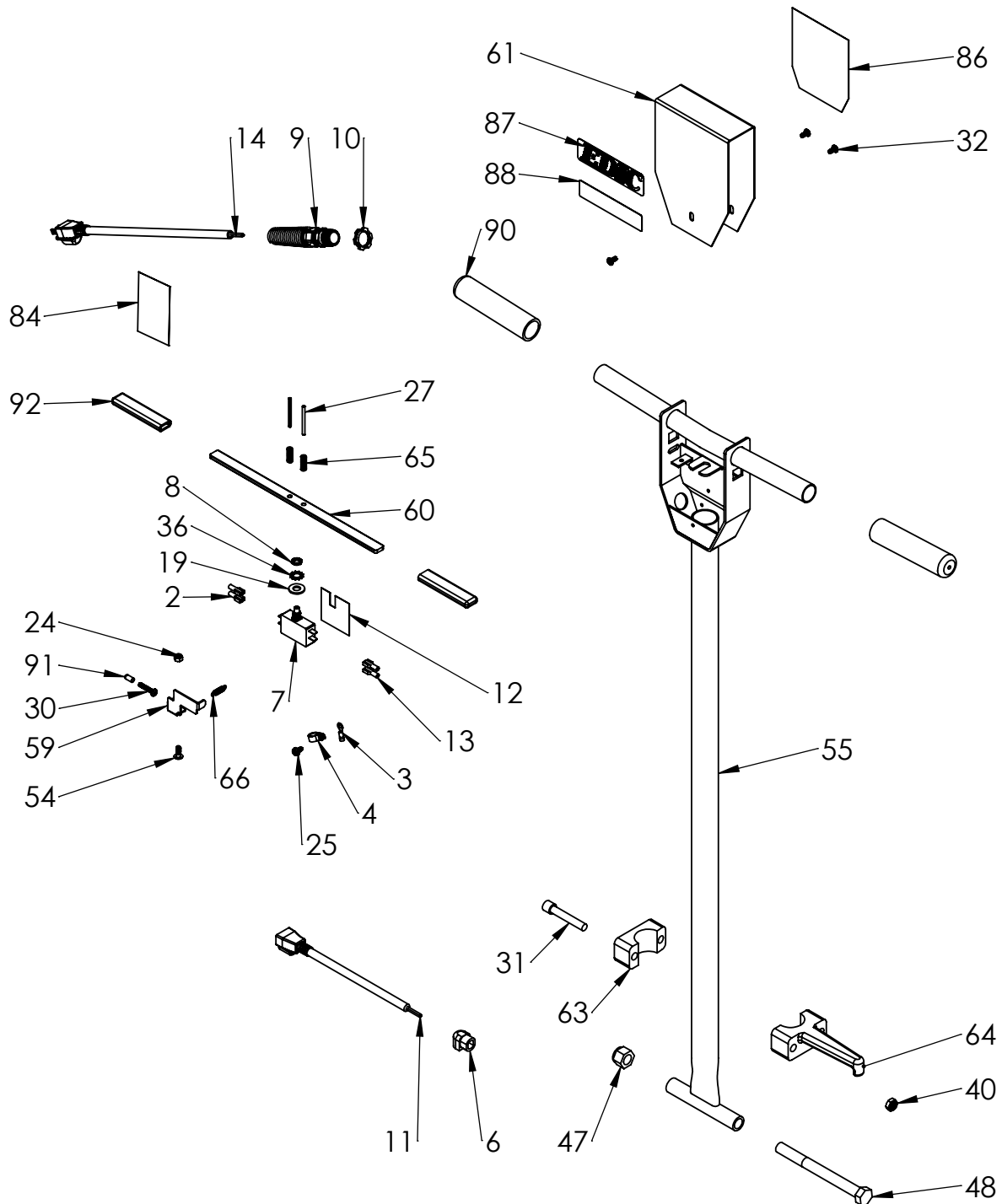



HS1500-BK-SV  
HS FLOOR MACHINE  
PARTS LIST

ITEM NO.	PART NUMBER	DESCRIPTION	QTY.
1	2400BR	PAD HOLDER, HIGH SPEED, 20"	1
2	B00177	TERMINAL LUG, QD F 16-14AWG, F.INS	2
3	B00180-10-3	RING TERMINAL, 16-14AWG, P.INS	1
4	B00187	CABLE CLAMP, NYLON .43	1
5	B02196-1	INDICATOR LIGHT	1
6	B10734	STRAIN RELIEF, HANDLE	1
7	B11465	SWITCH, DPST PUSH BUTTON	1
8	B11465-NUT	NUT, SWITCH	1
9	B11504	STRAIN RELIEF	1
10	B11505	LOCKNUT, STRAIN RELIEF	1
11	B11513	POWERCORD, 14GA	1
12	B11518	INSULATION PAPER	1
13	B11762	TERMINAL LUG, QD F, 12-10AWG, F.INS	2
14	B11900	POWERCORD, 12GA	1
15	C00233	WASHER, FLAT, USS 1/4	2
16	C00240	SHOULDER WASHER, NYLON	6
17	C00250	LOCK WASHER, 3/8 SPLIT	3
18	C00251	LOCK WASHER, 5/16, SPLIT	4
19	C00252	WASHER, 3/8 x 13/16	1
20	C00252-1	WASHER, 3/8	6
21	C00259	WASHER, SLOTTED	1
22	C00261	HEX NUT, 1/4-20	6
23	C00262	HEX NUT, 5/16	4
24	C00278	LOCKNUT, 10-32, NYLON, SS	1
25	C00284	SCREW, 10-32 x 3/8, GND	1
26	C00297	SCREW, #8 x 1/4 SMS, SS	2
27	C00306	ROLL PIN	2
28	C00319-1	HEX SCREW, 1/4-20 X 3 1/2", SS	2
29	C02305	PUSH NUT	2
30	C11491	SCREW, 10-32 X 1" SS	1
31	C11502	SCREW, 3/8-16, SHCS	1
32	C11529	SCREW, 10-32 x .375, PH BLK OX	9
33	C11536-1	SPADE BOLT	1
34	C11537	DOWEL PIN	1
35	C11538	PUSH NUT	1
36	C11541	LOCKWASHER, 3/8, EXT. STAR	1
37	C11555	KEY, 316	2
38	C11556	WAVE WASHER	2
39	C11558	LOCKNUT, 3/8-16	2



HS1500-BK-SV  
HS FLOOR MACHINE  
PARTS LIST

ITEM NO.	PART NUMBER	DESCRIPTION	QTY.
40	C11558	LOCKNUT, 3/8-16	2
41	C11559-1	WASHER, 1/2	4
42	C11567	SET SCREW	3
43	C11568-1	HEX BOLT, 5/16 X 2.5, SS	4
44	C11569-1	SCREW, 3/8 X 1.25, HH, SS	4
45	C11571-1	SCREW, 3/8 X 3/4, HH, SS	3
46	C11574	RETAINING RING	2
47	C13100	NUT, M14	1
48	C13101	SCREW, M14	1
49	C14150	WASHER, 3/8 NYLON	2
50	C14724	SCREW, 1/2-13 x 3, HEX, ZINC PLATED	2
51	C14725	LOCKNUT, 1/2-13, ZINC PLATED	2
52	C14726	SCREW, 3/8-24 x 1 1/2 L, HEX	2
53	C14727	HEX NUT, 3/8-24, ZINC PLATED	4
54	C90007-1	SHOULDER SCREW, 10-32	1
55	D11479	HANDLE	1
56	D11486	PAD COVER, 20	1
57	D11490B-1	DRIP COVER	1
58	D11490B-1-H	DRIP COVER W/ LIGHT	1
59	D11494	SAFETY LOCK BRACKET	1
60	D11495	TRIGGER	1
61	D11496	COVER, SWITCH BOX	1
62	D11497	HANDLE, LOCKING CLAMP	1
63	D11507	CORD HOOK, CLAMP	1
64	D11507-2	CORD HOOK, BODY	1
65	D11523-1	TRIGGER SPRING, 3/8" OD	2
66	D11524	SPRING, LOCKOUT	1
67	D11526-1	BASE	1
68	D11532	PULLEY, 2" W/ GROOVES	1
69	D11547	PULLEY, 1500 RPM	1
70	D11534	SHAFT	1
71	D11535	WASHER, 1.75 OD, STEEL	1
72	D11542	BRACKET, TENSION ADJUSTMENT	2
73	D11543	HANDLE BRACE, L BK HS	1
74	D11544	HANDLE BRACE, R BK HS	1
75	D11545	MOTOR SCREEN, HIGH SPEED	1
76	D11562	AXLE, WHEEL, HISPEED	1
77	D11565	HOUSING, BEARING	2
78	E11478	BUMPER	1
79	F11988	PAD, HIGH SPEED, 20"	1



HS1500-BK-SV  
HS FLOOR MACHINE  
PARTS LIST

ITEM NO.	PART NUMBER	DESCRIPTION	QTY.
80	G11531	BEARING	2
81	G11557	MOTOR, HIGH SPEED	1
82	G11943	WHEEL, 5"	4
83	H00565-5	LABEL, SERIAL #, STANDARD	1
84	H02548-2	LABEL, CORD	1
85	H03545	COVER, SERIAL # LABEL	1
86	H11493	SAFETY LABEL	1
87	H11831	EDIC LABEL	1
88	H12070	LABEL, 1500RPM	1
89	K00662-500	SPACER	2
90	K11498	GRIP, HANDLE	2
91	K11519	CAP, LOCKOUT BRACKET	1
92	K11520	GRIP, LEVER	2
93	K14145	SPACER, 1.48L	2
94	K14709	PLUG, RATCHET, .281D x .891L	2
95	L11530	BELT	1



HS2000-BK-SV  
HS FLOOR MACHINE  
PARTS LIST

ITEM NO.	PART NUMBER	DESCRIPTION	QTY.
1	2400BR	PAD HOLDER, HIGH SPEED, 20"	1
2	B00177	TERMINAL LUG, QD F 16-14AWG, F.INS	2
3	B00180-10-3	RING TERMINAL, 16-14AWG, P.INS	1
4	B00187	CABLE CLAMP, NYLON .43	1
5	B02196-1	INDICATOR LIGHT	1
6	B10734	STRAIN RELIEF, HANDLE	1
7	B11465	SWITCH, DPST PUSH BUTTON	1
8	B11465-NUT	NUT, SWITCH	1
9	B11504	STRAIN RELIEF	1
10	B11505	LOCKNUT, STRAIN RELIEF	1
11	B11513	POWERCORD, 14GA	1
12	B11518	INSULATION PAPER	1
13	B11762	TERMINAL LUG, QD F, 12-10AWG, F.INS	2
14	B11900	POWERCORD, 12GA	1
15	C00233	WASHER, FLAT, USS 1/4	2
16	C00240	SHOULDER WASHER, NYLON	6
17	C00250	LOCK WASHER, 3/8 SPLIT	3
18	C00251	LOCK WASHER, 5/16, SPLIT	4
19	C00252	WASHER, 3/8 x 13/16	1
20	C00252-1	WASHER, 3/8	6
21	C00259	WASHER, SLOTTED	1
22	C00261	HEX NUT, 1/4-20	6
23	C00262	HEX NUT, 5/16	4
24	C00278	LOCKNUT, 10-32, NYLON, SS	1
25	C00284	SCREW, 10-32 x 3/8, GND	1
26	C00297	SCREW, #8 x 1/4 SMS, SS	2
27	C00306	ROLL PIN	2
28	C00319-1	HEX SCREW, 1/4-20 X 3 1/2", SS	2
29	C02305	PUSH NUT	2
30	C11491	SCREW, 10-32 X 1" SS	1
31	C11502	SCREW, 3/8-16, SHCS	1
32	C11529	SCREW, 10-32 x .375, PH BLK OX	9
33	C11536-1	SPADE BOLT	1
34	C11537	DOWEL PIN	1
35	C11538	PUSH NUT	1
36	C11541	LOCKWASHER, 3/8, EXT. STAR	1
37	C11555	KEY, 316	2
38	C11556	WAVE WASHER	2
39	C11558	LOCKNUT, 3/8-16	2



HS2000-BK-SV  
HS FLOOR MACHINE  
PARTS LIST

ITEM NO.	PART NUMBER	DESCRIPTION	QTY.
40	C11558	LOCKNUT, 3/8-16	2
41	C11559-1	WASHER, 1/2	4
42	C11567	SET SCREW	3
43	C11568-1	HEX BOLT, 5/16 X 2.5, SS	4
44	C11569-1	SCREW, 3/8 X 1.25, HH, SS	4
45	C11571-1	SCREW, 3/8 X 3/4, HH, SS	3
46	C11574	RETAINING RING	2
47	C13100	NUT, M14	1
48	C13101	SCREW, M14	1
49	C14150	WASHER, 3/8 NYLON	2
50	C14724	SCREW, 1/2-13 x 3, HEX, ZINC PLATED	2
51	C14725	LOCKNUT, 1/2-13, ZINC PLATED	2
52	C14726	SCREW, 3/8-24 x 1 1/2 L, HEX	2
53	C14727	HEX NUT, 3/8-24, ZINC PLATED	4
54	C90007-1	SHOULDER SCREW, 10-32	1
55	D11479	HANDLE	1
56	D11486	PAD COVER, 20	1
57	D11490B-1	DRIP COVER	1
58	D11490B-1-H	DRIP COVER W/ LIGHT	1
59	D11494	SAFETY LOCK BRACKET	1
60	D11495	TRIGGER	1
61	D11496	COVER, SWITCH BOX	1
62	D11497	HANDLE, LOCKING CLAMP	1
63	D11507	CORD HOOK, CLAMP	1
64	D11507-2	CORD HOOK, BODY	1
65	D11523-1	TRIGGER SPRING, 3/8" OD	2
66	D11524	SPRING, LOCKOUT	1
67	D11526-1	BASE	1
68	D11532	PULLEY, 2" W/ GROOVES	1
69	D11533	PULLEY, 3 1/8, 2000 RPM	1
70	D11534	SHAFT	1
71	D11535	WASHER, 1.75 OD, STEEL	1
72	D11542	BRACKET, TENSION ADJUSTMENT	2
73	D11543	HANDLE BRACE, L BK HS	1
74	D11544	HANDLE BRACE, R BK HS	1
75	D11545	MOTOR SCREEN, HIGH SPEED	1
76	D11562	AXLE, WHEEL, HISPEED	1
77	D11565	HOUSING, BEARING	2
78	E11478	BUMPER	1
79	F11988	PAD, HIGH SPEED, 20"	1



HS2000-BK-SV  
HS FLOOR MACHINE  
PARTS LIST

ITEM NO.	PART NUMBER	DESCRIPTION	QTY.
80	G11531	BEARING	2
81	G11557	MOTOR, HIGH SPEED	1
82	G11943	WHEEL, 5"	4
83	H00565-5	LABEL, SERIAL #, STANDARD	1
84	H02548-2	LABEL, CORD	1
85	H03545	COVER, SERIAL # LABEL	1
86	H11493	SAFETY LABEL	1
87	H11831	EDIC LABEL	1
88	H12069	LABEL, 2000RPM	1
89	K00662-500	SPACER	2
90	K11498	GRIP, HANDLE	2
91	K11519	CAP, LOCKOUT BRACKET	1
92	K11520	GRIP, LEVER	2
93	K14145	SPACER, 1.48L	2
94	K14709	PLUG, RATCHET, .281D x .891L	2
95	L11530	BELT	1